



**Thanks for choosing our Rallycross Coilover Kit for your NA/NB Miata! We've spent countless hours of fitting, testing, and multiple design iterations developing this kit to provide a perfectly balanced setup with the absolute maximum amount of wheel travel possible while retaining the factory control arms. It's a great performing suspension with enough versatility and adjust-ability to conquer virtually any level of terrain while retaining good road manners. We hope you find the product to be of quality design and construction, and these instructions to be straightforward and thorough. Please read through these instructions 100% before you begin.**

**NOTES:** This kit will add 1"-4" of ride height depending where you position the spring collars. On all cars, you will need to drill out the shock mounting holes in the front lower control arms a small amount using a 1/2" drill bit. On NB cars (1999-2005) it's required to remove some metal in the shock tower holes for the inverted shocks and mounts to fit. We also HIGHLY recommend using this kit in conjunction with our adjustable rear upper control arms and extended front lower ball joints for optimum wheel alignment and handling. A wheel alignment is 100% necessary once the kit is installed and set to the desired ride height. Car shown above is set at roughly +3.5" ride height with fenders cut and eBay flares added. Tires are ~28" diameter.

**WARNING:** Not everyone can perform every installation. It is critical that you be honest with yourself in regards to your ability. We're more than happy to help, but there are only so many things we can do from the other end of a phone / computer. If in doubt, discuss the install with us before you dive in. Improper installation could result in vehicle damage or injury. Customer assumes full responsibility with the installation and use of this kit. We are not responsible for any law breakage, vehicle breakage, or people breakage.

## Parts List:

- 2x - Front Shock (PM-RX-30-7436)  
w/ threaded perch and HD bumpstop
- 2x - Rear Shock (PM-RX-30-7325)  
w/ threaded perch and HD Bumpstop
- 2x - Front Spring (200/425)
- 2x - Rear Spring (175/350)
- 2x - Front Upper Mount
- 2x - Rear Upper Mount
- 2x - Rear Lower Mount (R+L)
- 8x - M8x30mm Flange Bolt
- 2x - M8x75mm Bolt
- 10x - M8 Flange Nut
- 16x - M8 Flat Washer
- 2x - 1/2" x 2" Grade 8 Bolt
- 2x - 1/2" x 2.5" Grade 8 Bolt
- 2x - 1/2" x 3" Grade 8 Bolt
- 2x - 1/2" x 4" Grade 8 Bolt
- 6x - 1/2" Nylon lock nut
- 2x - 1/2" Split-lock washer
- 22x - 1/2" Flat Washer
- 6x - 3/4" Aluminum Spacer
- 4x - 3/8" Aluminum Spacer
- 2x - 11/32" Aluminum Spacer
- 1x - Spanner Wrench



Rear Upper Mount

Front Upper Mount



Rear Lower Mounts RH+LH



## Installation:

1. Raise the car securely on jack stands or a lift.
2. Remove wheels and swaybar links all around.
3. Loosen all control arm bolts.
4. Remove lower shock bolts all around.
5. Loosen M8 shock tower nuts underhood and inside trunk (2 per shock) and remove rear coilover assemblies.

6. Remove inner pivot bolt on front upper control arms and pivot hub assembly outward, being careful not to damage the brake lines.

7. Remove the front coilover assemblies and loosely reinstall pivot bolt through control arm to hold the hub in place.

8. Install the Rear Upper mounts up through the shock holes and into the trunk area. **NB cars require material to be removed from the hole to make a 3"x2" rectangular opening.** Secure with M8 hardware. (25 ft/lb) -- fig.1

9. Now install the rear shock upside-down into the trunk area and loosely hang it there with the hardware as shown. -- fig.1

10. Install the rear spring over the shock and and the lower rear mount into the lower control arm at the same time, positioning the parts and hardware as shown in fig.2 and fig.3. The lower mount will be installed in the control arm using the factory bolt.

11. Tighten the factory bolt to 60 ft/lb and tighten the new top and bottom 1/2" shock bolts to 75ft/lb.

12. Turn spring perch collar until spring is properly located in its mounts and hand tight.

13. Install M8x75mm bolt through the bottom of the control arm and fasten with a washer on each side and nylon locking nut. (25 ft/lb) fig.3

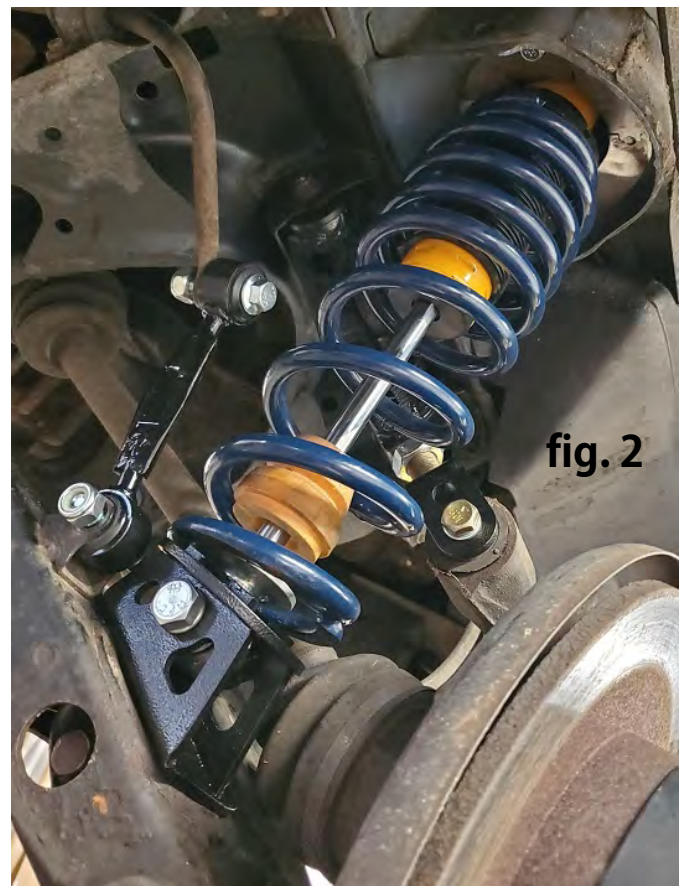
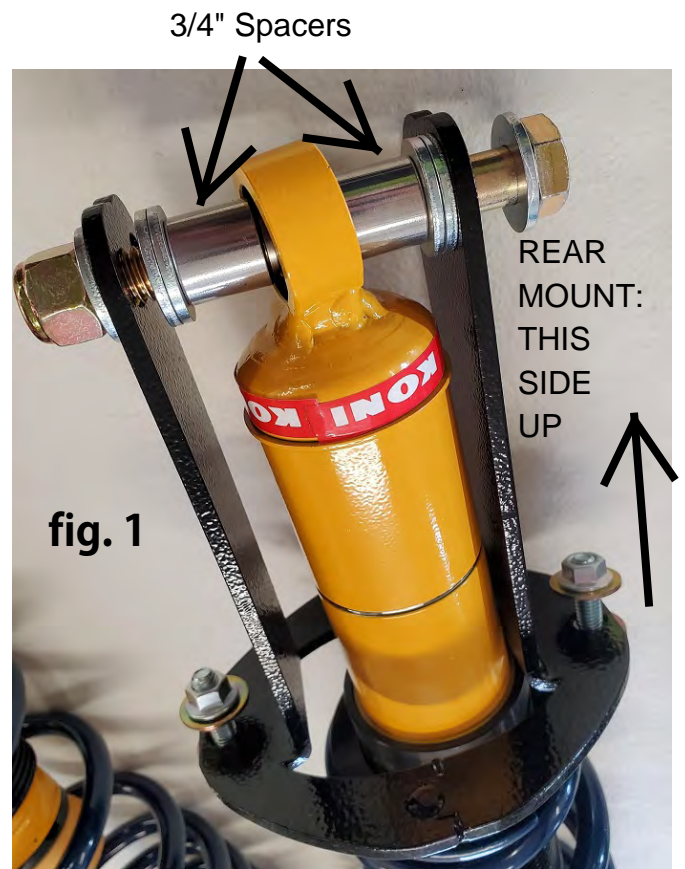

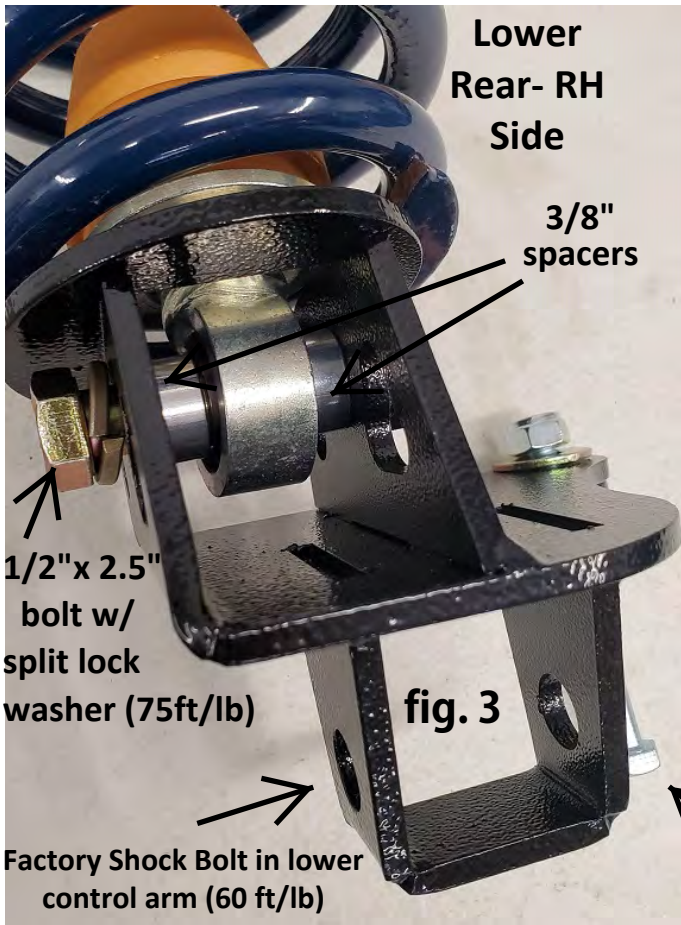

M8x75mm bolt w/ 2 flat washers and nylon locking nut through lower control arm (25 ft/lb)

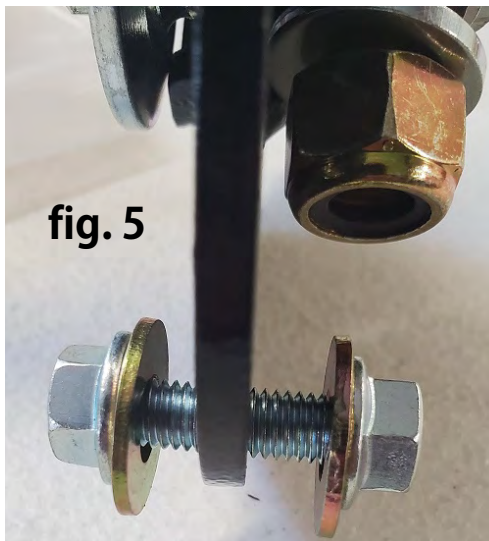

Install M8 hardware on upper mounts as shown  
25 ft/lb (8 places on car)

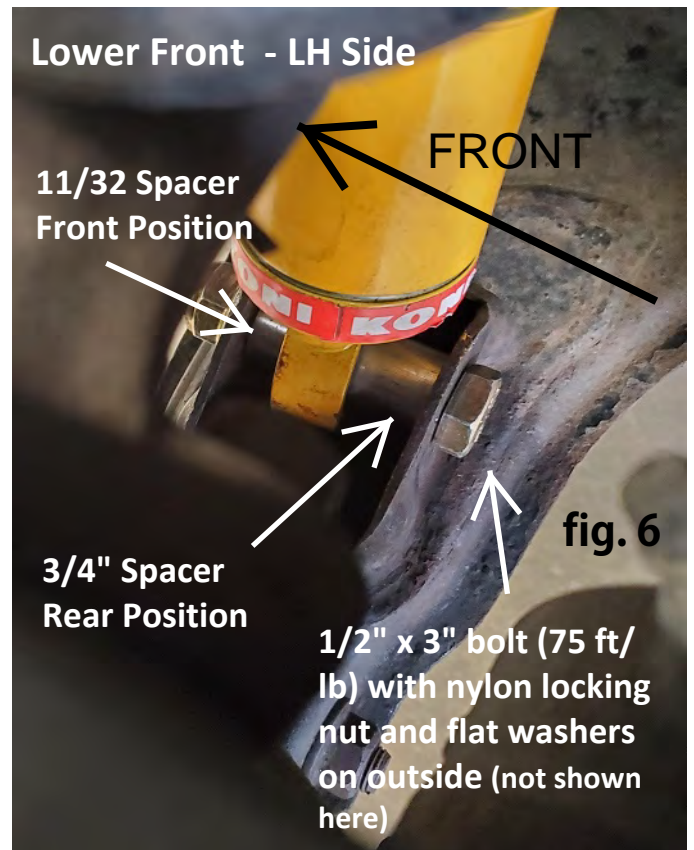

14. On the front control arms, drill out the lower shock bolt tabs to 1/2" diameter. -- fig.6

15. Install the front spring over the front shock body. The front shock piston goes into the upper mount as pictured with 1/2" x 2" bolt, nylon locking nut, and 3 washers. (75 ft/lb) -- fig.4

16. With the inner control arm bolt removed again, install the shock assembly down through the upper control arm and into the lower control arm tabs. Use the 1/2" x 3" bolt, 11/32" and 3/4" spacers, washers, and nylon locking nut as pictured. (75 ft/lb) -- fig.6

17. Install the upper mount using the M8 hardware as pictured. (25 ft/lb) -- fig.5 --**NB cars require some trimming for the bolt/nut to fit through the shock tower hole.**

18. Turn spring perch collar until spring is properly located in its mounts and hand tight.

19. Once all fasteners are torqued, reinstall the wheels/tires and lower car to the ground.

20. As necessary, adjust ride height with the spring collars and spanner wrench, and then proceed with four wheel alignment. Be sure to **ONLY** torque the control arm pivot bolts with the weight of the car on the suspension at rest.

### Important notes about ALL Lifted Miatas with factory control arms:

- As you raise a Miata above stock ride height, the suspension geometry causes the front camber to go more positive, and the rear camber to go more negative. In the front, it is recommended to use our extended lower ball joints to get back to more ideal camber settings. In the rear, it is recommended to install our adjustable upper control arms to push the top of the spindle more outward to reduce negative camber which can also help with inner tire to spring clearance AND prevents premature wear and breakage of CV joints running at extreme angles.

- Stock rear swaybar endlinks will prevent full range of wheel travel. We offer extended end links to fix this problem. This is only an issue with the rear links.

## **Important notes about ALL Lifted Miatas with factory control arms:** **(continued)**

- Tire sizes that fit can range vastly from one application to the next, but in general, ~25-26" diameter tires are about as big as will fit without extensive fender and bumper modifications. 29" and even 30" tires have been fitted in extreme cases with lots body mods. Be aware that although taller tires will get you higher off the ground, you can limit full wheel travel in the upward direction if you go too big. You will also lose acceleration with larger tires. The final drive ratio is changed, reducing torque, not to mention you're spinning a heavier wheel/tire mass. Our 5.38:1 differential gearset can help get back some of that acceleration.
- In an offroad situation, you will have a more stable handling car if you keep the ride height as low as possible for the terrain you're on. This allows the suspension to "droop" over low areas and the tires will still be in contact with the ground. Raise the car too high and the ride gets stiffer and less predictable.
- Soon after we began lifting Miatas, we were impressed how well they performed and held up to relatively extreme use. That said, these cars are not indestructible and things will break with extreme use. CV axles can be easily broken with a combo of high ride height, rough terrain, and a lead foot. Stock replacements are cheap, and higher strength axles are readily available.